

SUMTOR

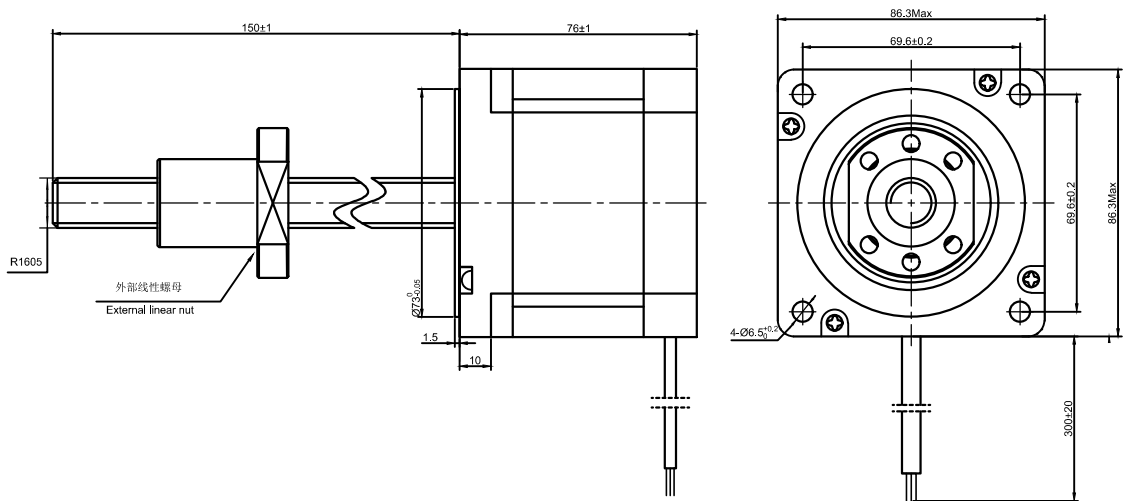

绕组接线图

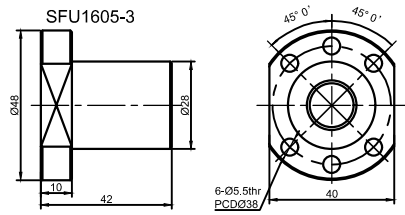
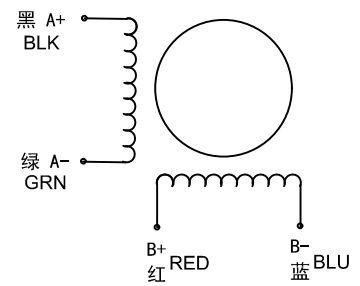

外形尺寸: unit=mm

Electrical Specifications			COMMENT	螺杆规格 The screw shaft specifications	
STEP ANGLE	步距角	1.8 ° /STEP	未注线性与角度尺寸公差 Tolerances for liner and angular dimensions without individual tolerance indications GB/T 1804-m eqv IOS 2768-1:m 未注形状与位置尺寸公差 Geometrical tolerance for features without individual tolerance indications GB/T 1184-K eqv IOS 2768-2:K	规格Modle	R1605
RATED VOLTAGE	相电压	2.0 V		步长Resolution	0.025mm
CURRENT	相电流	5.6 A/PHASE		导程Lead	5
RESISTANCE	相电阻	0.35 Ω/PHASE		型号Nut NO:	SFU1605-3
INDUCTANCE	相电感	2.8 mH/PHASE			
HOLDING TORQUE	静力矩	450 N.cm			
ROTOR INERTIA	转动惯量	1400 g.cm ²			
MOTOR LENTH	机身长度	76 mm			
LEAD WIRE	引线数	4 NO			
MOTOR WEIGHT	重量	2500 g			

序号	数量	名称/代号/材料			
设计	审核	批准	日期	图号	比例
张百灵	孙灵山		2023/3/29	86HS	1:1
无锡三拓电气设备有限公司 SUMTOR(Wuxi) Electric CO., Ltd			86HZ7656R16C5-150		
项目	86步进丝杆电机			版本	V2.0